

IMPORTANT : We are continuously making technical improvements to our products; before starting any work, our customers should check with us that this document is still in force through Gerflor's website.

Examine the floor covering prior to installation to ensure that there are no visual defects. If a visual defect is detected, please inform GERFLOR and do not begin installation until you receive approval to proceed.

GENERAL

The floor covering must be laid by a specialist contractor who is familiar with the specific features of this product and the laying requirements. The laying requirements primarily relate to the dimensional instability of linoleum caused by relative humidity if it is inadequately glued down. The product is also very rigid, requiring great skill when cutting the sheet edge and making adjustments.

Gerflor recommends to follow and apply local standards. In case of absence of local standards, the recommendations below must be considered.

NOTE 1 : During the natural curing process a yellowing haze will occur on the Linoleum. As soon as the Linoleum is exposed to light this yellowing haze will recede. When exposed to direct sunlight the yellowing will disappear after a short time period; when exposed to artificial light or less sunlight several days or weeks may pass. Therefore rolls installed in the same area should be exposed to the same light conditions.

1. SUBSTRATES

As linoleum is sensitive to moisture, it's necessary to prevent moisture from the substrate.

For concrete screeds without any risk of moisture's increasing, moisture must be less than 2% by weight according to the carbide bomb test.

For calcium sulphate-based liquid screeds without any risk of moisture's increasing, less than 0.5% by weight according to the carbide bomb test.

Linoleum doesn't have any specific sportive performance as a material. Before installation, make sure you have all necessary documents from the sub-construction's or underlayer's supplier to attest the system is suitable with customer's requirements. Substrates specifications must be considered following sub-construction's or underlayer's supplier for their installation, considering especially that moisture must be prevent.

2. MATERIALS

LINOLEUM SUITABLE FROM GERFLOR FOR SPORT USE ARE AS FOLLOW:

- Marmorette Sport : product of 3,2 mm without varnish,
- Linodur Sport : product of 4 mm with Neocare varnish,
- Colorette Sport : product of 4 mm with Neocare varnish.

3. VENUE AND LAYING CONDITIONS

■ 3.1 - STORING THE MATERIALS ON JOBSITE

Care must be taken not to drop the rolls when they are unloaded.

The materials involved in laying glue-down linoleum floor coverings must be acclimatised for 48 hours before laying, in an enclosed, ventilated and secure room, protected from moisture and excessive heat, in ambient conditions identical to those set out below, and on a dry substrate. Room temperature must be at least +18°C.

They must be stored vertically. The rolls are cut a day or two in advance, stored upright and loosened.

Unpacked rolls stored in the gymnasium before being unrolled must not be exposed to direct sunlight, because ageing may occur on the exposed part of the roll.

■ 3.2 - TEMPERATURE AND HUMIDITY:

The minimum substrate temperature required for laying is +15°C and a room temperature of +18°C. The humidity must not exceed 65% while work is being carried out. The humidity and the substrate temperature must be such that there is no condensation on the substrate (dew point).

4. UNROLLING THE MATERIAL (at least 24 hours before gluing down)

After measuring the air humidity any dirt must be vacuumed off the substrate. After this the actual installation of the sheets can begin. When arranging and cutting the sheets always proceed in the order of the roll numbers. The sheets must always be installed from one longitudinal wall to the other sequentially based on ascending roll numbers (max difference between one sheet and the one next to it: 20). Head seams are only allowed for sheets with a length of more than 5 meters.

Makes sure that the end of the sheets are always at least 5 cm up against the walls when installing.

The ends are not cut until after gluing.

1	2
3	4
5	6
7	8
9	10



Both edges of the Linoleum sheet must always be cut. The first sheet edge is cut with the linoleum edge cutter or strip cutter (approx. 1.5-2 cm). The second sheet is laid over the already trimmed sheet edge, overlapping by approx. 2cm along its entire length. Subsequently the edge cut is made opposite the overlapping side just like the first sheet.

5. GLUING, FITTING AND SMOOTHING

Linoleum sheets are usually glued and fitted one by one. As such, fitting may precede gluing.

■ 5.1 - GLUING RULES

The surface is always glued over the entire area. The installation guidelines of the adhesive manufacturer must always be respected. Sport Linoleum is bonded with dispersion adhesives dedicated to linoleum. The adhesive must be applied with a toothing and consumption in accordance with the manufacturer's recommendation. Most of the time, adhesive suitable for Linoleum are used B1 spatula (according to TKB standard).

Double application of adhesive must be avoided.

Linoleum sheets are always placed into the fresh (wet) adhesive bed in the same order as the sheets are arranged and cut and the sheet should be counter-rolled at the end.

It is recommended to glue only individual sheets at a time.

Air pockets must be avoided or rubbed out laterally.

Tips:

- It is helpful if the borders of the installation section for adhesive application are marked on the substrate with chalk/pencil. Then adhesive should be only applied in the area where a sheet can be applied during the wet phase of the adhesive. The adhesive must still be capable of wetting well and must be slightly compressible.
- To prevent cracking, soften the ends of the sheet with forward and back movements when you place them onto the adhesive.
- The head end of the sheets (wall) are pressed into the adhesive via counter-rolling and counter pressing.



■ 5.2 - FITTING TIPS

There are two ways to cut Linoleum.

- Freehand using a hot air tool, after gluing and smoothing out.
- By scribing after most of the sheet has been glued down (approximately 10 to 12 m).

■ 5.2.1 - End sheets overlapping

The upper edge of the sheet is scribed with the scriber or Linocut along the already trimmed edge of the sheet already pressed in the adhesive. The sloping strip is cut out with the hook knife in a way that the back of the hook knife can slide freely through the joint. The required joint of at least 0,5-1mm is then achieved.

■ 5.2.2 - Along the wall



Place the sheet to cut on the sheet beside making sure it is correctly aligned (edges must be parallel).

Using a large scribe adjusted to the offset of the sheet, mark the profile of the wall onto the flooring.

Use a knife with a hooked blade to cut the linoleum.

Place the sheet along the wall for gluing.

■ 5.2.3 - End sheets to the wall

- Stop applying adhesive to the substrate at a line drawn 1.50 ml from the edge of the wall (perpendicular to the material).
- Glue down and smooth the material up to this line.
- Draw a reference mark on the floor covering and the substrate (1).
- Slide a cardboard core under the unglued section of linoleum, positioning it so it is parallel to the line you drew earlier, to release the end of the sheet to the wall. An offset is present between references drawn before (2).
- Adjust the scribe device between the two marks (3).
- Carry out scribing and cut the end as described above (4).
- Remove the core, apply adhesive, glue down the material and smooth down the end of the sheet.
- Repeat these steps for each end, taking care not to crack the linoleum while handling it.

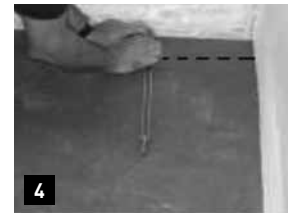
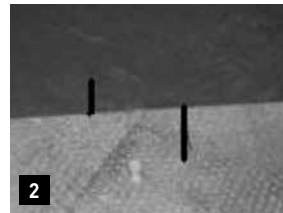

■ 5.2.4 - Finishing around door frames

Use a heater to soften the linoleum for easier cutting.

■ 5.3 - SMOOTHING

It is done in two times:

- Manual smoothing when the material is laid onto adhesive, using a cork block or a heavy hammer for linoleum's smoothing.
- Over the entire surface using a smoothing roller (heavy, about 80 kg), to ensure that the adhesive coats the back of the floor covering successfully.

Tips:

- The seams and edges of all the sheets must be carefully rubbed with a heavy hammer approx. 20 minutes after insertion in the adhesive.
- Air must not be trapped during insertion, if such it should be rubbed out laterally.
- Air spots, which can be spotted by going over the covering with a heavy hammer, can be pierced so the air can be pressed out. After piercing, put some weight on the spot to insure adhesion.

6. HOT WELDING (48h after gluing)

Hot welding (more accurately thermal bonding because the welding cord is different) is carried out as follows:

■ 6.1 - GROOVING

Grooving allows the joint to be opened and corrected, to remove any traces of adhesive that may impair the quality of the weld.

There are two grooving methods:

- Manual using an appropriate tool (triangle, rule, etc.)
- Mechanical using an electric grooving machine fitted with a 3.3 to 3.5 mm bit

Joints between sheets have to be grooved out to a depth of 2/3 of the linoleum thickness and carefully vacuumed or blown out.

■ 6.2 - AUTOMATIC WELDING MACHINE

Welding is carried out using a LEISTER UNIVERSAL or UNIFLOOR hot air welding machine fitted with a narrow multi-outlet nozzle designed for this purpose. Temperature can be from 350°C to 450°C. The working speed is selected so that the melted welding rod runs well into the grooved seam.

Nozzle codes:

ROMUS : 95253

JANSER : 225 860 300 + 225 865 310 for Leister Universal

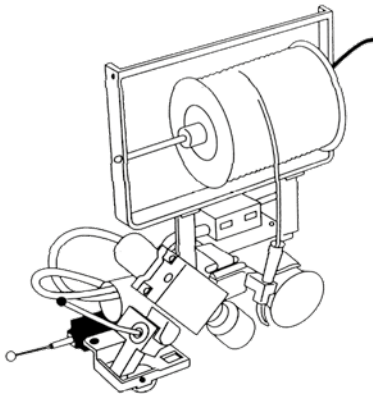

■ 6.3. HAND WELDING WITH AN ULTRA SPEED NOZZLE

Use the «RAPID ULTRA» nozzle (diameter 5 mm, air vent 0.9 mm). Ref.: JANSER 224 800 007 or ROMUS 95027.

■ 6.4 - TRIMMING

The surplus part of the welding rod is taken away in two stages. The first trimming is carried out while the welding rod is still warm, using the Mozart knife with the thickness guide for linoleum.

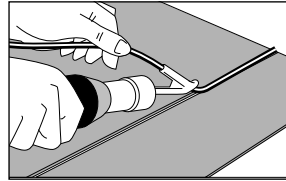

After the welding rod has cooled down the second trimming is performed using the Mozart knife without any thickness guide.

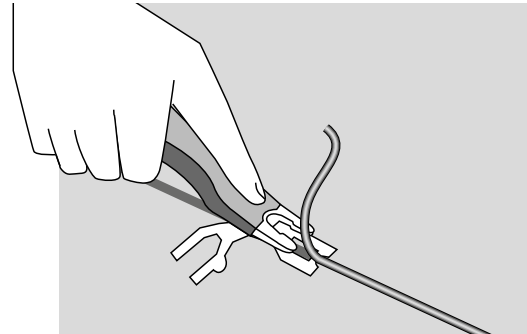

7. GAME LINES

Marmorette Sport is delivered without any varnish.

We recommend to use KIPP 2 K PUR Indoor Marking or CONICA Conipur 3100 PU paintings according to their recommendations.

You are advised to apply a protective varnish for linoleum surfaces that meets the requirements of EN 14904 / DIN 18302 (indoor surfaces for multi-sports use).

When applying the surface treatment, carefully follow the manufacturer's recommendations (cleaning the surface before application, conditions for applying the product, drying, first use, renovation, etc.).

Non-exhaustive list of product manufacturers:

Buzil - <https://www.buzil.fr/home.html>

Dr Schutz - <https://www.dr-schutz.com/>

Kipp retailer (<https://kipp-markierungen.de/>)

Colorette Sport and Linodur Sport benefit of varnish. We recommend to use KIPP 2 K PUR Indoor Marking or BONA SuperSport Line paintings according to their recommendations.

There is no need to apply a protective varnish.

8. FINAL CLEANING

Afterwards, give the area an initial clean with a neutral or redispersible detergent (pH < 9) that complies with the standard governing slip resistance. Refer to the cleaning and maintenance instructions for LINOLEUM SPORT.

IMPORTANT: times before first use:

- For normal traffic, the floor can be walked on 48 hours after the work has finished.
- Wait 72 hours before installing sports equipment or moving loads on wheel.
- Static and dynamic loads must be evenly distributed when installing equipment, such as folded and open table tennis tables, referee tables, solid storage trolleys, removable basketball boards, apparatus, platforms, forklifts and utilities. Raceways and distribution plates must be dimensioned and positioned according to the loads.

9. PUTTING INTO SERVICE - CIRCULATION

- Wait 48 hours before allowing normal foot traffic.
- Do not install fittings or furniture until 72 hours after laying.
 - Ensure that end caps on table and chair feet, and so on, are suitable for flexible floor coverings (PVC and linoleum) and will not damage the sports flooring.
 - We recommend flat end caps without any pattern and with the surface in full contact with the floor covering (no conical end caps).
 - Do not use rubber end caps.
 - Underfloor heating should not be switched on until at least seven days after the floor covering has been laid.

10. REPAIRS

In case of isolated repairs on small areas, there is no way to obtain the same shade. We recommend carrying out major repairs for a more aesthetic visual effect.